

## APPLICATION OF EUROCODE 3 TO STEEL CONNECTIONS WITH FOUR BOLTS PER HORIZONTAL ROW

**J.-F. Demonceau\*, K. Weynand\*\*, J.-P. Jaspart\*\*\* and C. Müller\*\*\*\***

\* Department Argenco, University of Liège, Belgium – in post-doctoral training at RWTH Aachen University, Germany  
e-mail: jfdemonceau@ulg.ac.be

\*\* Feldmann + Weynand GmbH, Aachen, Germany  
e-mail: k.weynand@fw-ing.de

\*\*\* Department Argenco, University of Liège, Belgium  
e-mail: Jean-Pierre.Jaspart@ulg.ac.be

\*\*\*\* Institute for Steel and Light Weight Structures, RWTH Aachen University, Germany  
e-mail: mul@stb.rwth-aachen.de

**Keywords:** Joints, Connections, 4 bolts per row, Component method.

**Abstract.** Eurocode 3 Part 1-8 provides detailed application rules for the design of bolted end-plate connections. Although these rules apply to connections with any number of bolt rows, they are limited to configurations with two bolts in each row. However, it is sometimes more economical to place four bolts in one row. This configuration is commonly met in different countries in Europe and, in particular, in Germany. The theoretical model on which the Eurocode 3 application rules are founded is general and can be potentially applied to connections with four bolts per row. However, specific design rules need to be developed. In the present paper, easy-to-apply analytical design rules aimed at predicting the mechanical properties of connections with four bolts per row and in full agreement with the Eurocode 3 approach are detailed. Validations through comparisons to experimental test results recently performed in the framework of a German national project are also presented.

### 1 INTRODUCTION

The analytical model recommended in the Eurocodes to characterise the mechanical properties of a joint is founded on the “component method” which is, nowadays, a widely recognised procedure for the evaluation of the design properties of structural joints. This method applies to any type of steel or composite joints, whatever the geometrical configuration, the type of loading (axial force and/or bending moment, ...) and the type of member sections. This method considers any joint as a set of individual basic components. For the particular joint shown in Figure 1 (steel joint configuration with an extended end-plate connection subjected to hogging bending moments), the relevant components are given.

Each of these basic components possesses its own strength and stiffness either in tension, in compression or in shear (spring model – see Figure 1). The column web is subjected to coincident compression, tension and shear. The coexistence of several components within the same joint element can obviously lead to stress interactions that are likely to decrease the resistance of the individual basic components; such interactions are taken into account within the method.

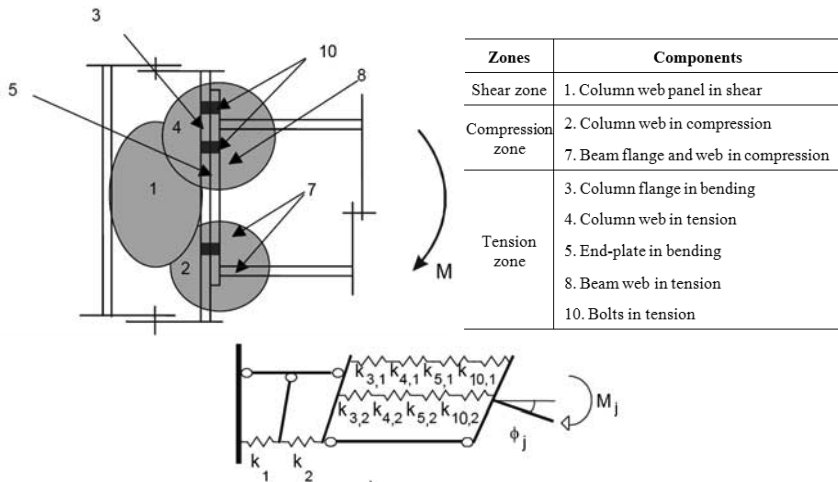

Figure 1: Steel joint with an extended end-plate connection subjected to hogging moments – Identification of the activate components – Spring model.

The application of the component method requires the following steps:

- identification of the active components in the joint being considered;
- evaluation of the stiffness and/or resistance characteristics for each individual basic component (specific characteristics - initial stiffness, design resistance, ... - or the whole load-deformation curve);
- assembly of all the constituent components and evaluation of the stiffness and/or resistance characteristics of the whole joint (specific characteristics - initial stiffness  $S_{j,ini}$ , design resistance  $M_{j,Rd}$ , ... - or the whole moment-rotation curve).

The assembly procedure consists in deriving the mechanical properties of the whole joint from those of all the individual constituent components. This requires a preliminary distribution of the forces acting on the joint into internal forces acting on the components in a way that satisfies equilibrium. In Eurocode 3 [1], an analytical assembly procedure is described for the evaluation of the initial stiffness  $S_{j,ini}$  and the design moment resistance  $M_{j,Rd}$  of steel joints. The application of the component method requires a sufficient knowledge of the behaviour of the basic components; as previously mentioned, most of the proposed design rules in the Eurocodes only cover joints with two bolts per row.

The components which are the most affected by the presence of four bolts instead of two are the components in bending, i.e. the “column flange in bending” and the “end-plate in bending”. In the following paragraph, the characterization of these components with four bolts per row is investigated in details.

## 2 COMPONENTS IN BENDING WITH FOUR BOLTS PER ROW

### 2.1 T-stub model

The design rules for these components, as suggested in the Eurocodes, are founded on the “T-stub approach”, firstly introduced by Zoetemeijer [2]. This approach consists in substituting to the tensile part of the connection by T-stub sections of appropriate effective length  $l_{eff}$ , connected by their flange onto a presumably infinitely rigid foundation and subjected to a uniformly distributed force acting in the web plate (Figure 2).

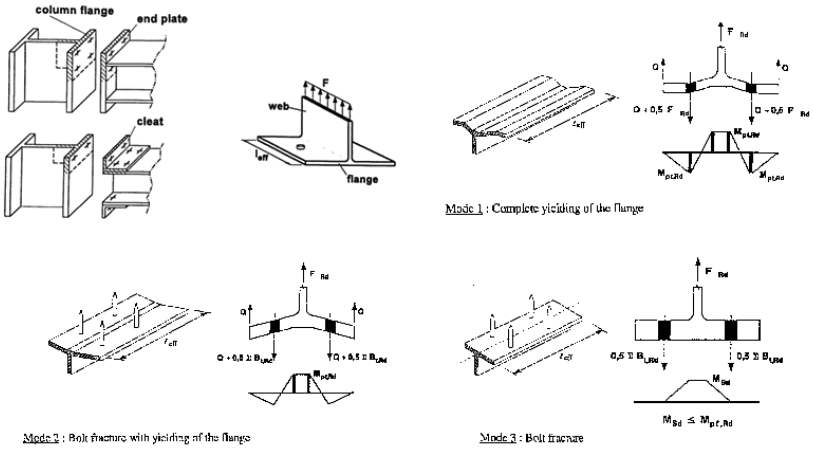

Figure 2: T-stub idealization and possible failure modes.

Through this approach, three different failure modes may be identified (Figure 2):

- Onset of a yield lines mechanism in the plate before the strength of the bolts is exhausted (Mode 1);
- Bolt fracture without prying forces, as a result of a very large stiffness of the plate (Mode 3) and;
- Mixed failure involving yield lines – but not a full plastic mechanism – in the plate and exhaustion of the bolt strength (Mode 2).

Within the Eurocodes, formulas to predict the design resistance of a T-stub flange with two bolts per row are given for each failure mode; the latter have been extended to T-stub configurations with four bolts per row (see Figure 3) in [3] and are reported in Table 1. Within this table, it can be observed that the formulas for Mode 1 and 3 remain unchanged; only the one related to Mode 2 is influenced by the “four bolts” and has to be adapted. This conclusion applies as long as the formulas are derived from a rigid-plastic theory; the latter may be fully justified for T-stubs with 2 bolts per row while it could possibly lead to unconservative results for T-stub with 4 bolts. For this reason, in [5],  $F_{Rd,3}$  is limited to  $0.9 \cdot \sum B_{t,Rd}$  according to [6] and [7]. Deeper investigations of this aspect are presently performed amongst the authors.

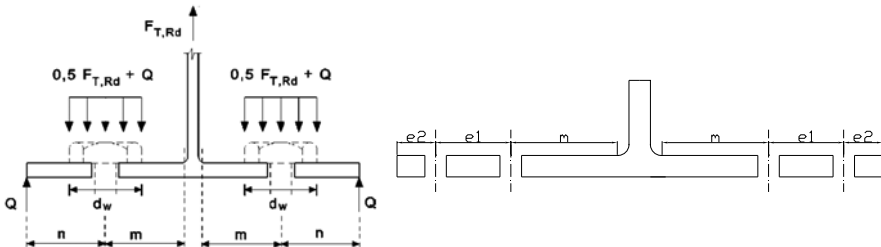

Figure 3: Definitions of the parameters for T-stubs with two or four bolts.

Table 1: Formulas to predict the design resistance of T-stubs for each possible failure mode.

Failure modes	T-stub with 2 bolts	T-stub with 4 bolts
Mode 1	$F_{Rd,1} = \frac{(8n - 2e_w)M_{pl,1,Rd}}{2mn - e_w(m+n)}$	$F_{Rd,1} = \frac{(8n - 2e_w)M_{pl,1,Rd}}{2mn - e_w(m+n)}$
Mode 2	$F_{Rd,2} = \frac{2M_{pl,2,Rd} + n \sum B_{t,Rd}}{m+n}$	$F_{Rd,2} = \min(F_{Rd,2,p}; F_{Rd,2,np}) \text{ with}$ $F_{Rd,2,p} = \frac{2M_{pl,2,Rd} + \frac{\sum B_{t,Rd}}{2} \cdot \left( \frac{n_1^2 + 2n_2^2 + 2n_1n_2}{n_1 + n_2} \right)}{(m + n_1 + n_2)}$ $F_{Rd,2,np} = \frac{2M_{pl,1,Rd} + \frac{\sum B_{t,Rd}}{2} \cdot n_1}{(m + n_1)}$
Mode 3	$F_{Rd,3} = \sum B_{t,Rd}$	$F_{Rd,3} = \sum B_{t,Rd}$ <p>(but limited in practice to <math>0,9 \sum B_{t,Rd}</math> ([6] &amp; [7])</p>

With:

- $m$  defined in [1] (see Figure 3);
- $e_w = d_w/4$  (see Figure 3);
- $\sum B_{t,Rd}$  sum of the design resistances of the bolts connecting the T-stub to the rigid foundation;
- $M_{pl,1,Rd} = 0,25l_{eff,1}t_f^2f_y / \gamma_{M0}$  ;
- $M_{pl,2,Rd} = 0,25l_{eff,2}t_f^2f_y / \gamma_{M0}$  ;
- $t_f$  the thickness of the T-stub flange;
- $f_y$  the yield strength of the T-stub steel;
- $l_{eff,1}$  minimum effective length associated to circular or non-circular patterns (see next paragraph);
- $l_{eff,2}$  minimum effective length associated to non-circular patterns (see next paragraph)
- For T-stub with 2 bolts,  $n$  is defined in Figure 3 with  $n \leq 1,25m$ ;
- For T-stub with 4 bolts,  $n = e_1 + e_2$  (see Figure 3) with  $n \leq 1,25m$ ,  $n_1 = e_1$  and  $n_2 = e_2$  with  $n_2 \leq 1,25m + n_1$ .

For the T-stub approach, the definition of accurate effective lengths is required; the values of the latter are mainly linked to the plastic mechanisms (made of plastic yield lines) which could developed within the considered component. Tables with analytical formulas to compute the latter are proposed in Eurocode 3 for an end-plate or a column flange with two bolts per row [1]. For the joint configuration with four bolts per row, the definition of such effective lengths was not available; it is the subject of the following paragraph.

## 2.2 Computation of the effective lengths for components in bending with four bolts per row

The presence of four bolts per row instead of two influences the development of the plastic yield lines within the components in bending. In Table 2, a summary of the analytical formulas to predict these effective lengths is given for outer bolt rows and inner bolt rows (see Figure 4), both for circular and non-circular yield patterns as defined in Eurocode 3 [1]; these formulas are based on the ones defined in [4]

for joints with two bolts per row. The parameters which are used in the formulas presented here below are defined in Figure 4; the computation of  $m_x$ ,  $m_1$ ,  $m_2$  and  $\alpha$  has to be performed in agreement with the Eurocode recommendation [1].

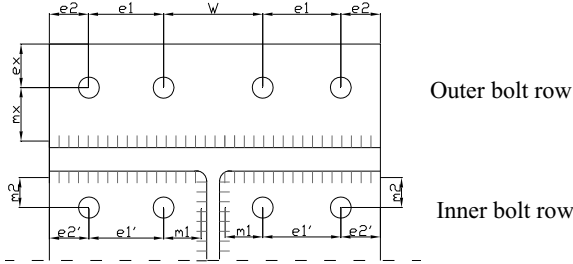

Figure 4: Definition of the parameters used in the computation of the effective lengths.

Table 2: Analytical formulas to predict the effective lengths for outer and inner bolt rows.

	Circular patterns	Non-circular patterns
	$l_{eff,c} = \min[l_{eff,I}; l_{eff,II}; l_{eff,III}; l_{eff,IV}]$	$l_{eff,nc} = \min[l_{eff,V}; l_{eff,VI}; l_{eff,VII}; l_{eff,VIII}; l_{eff,IX}]$
Outer bolt row	$l_{eff,I} = 4\pi m_x$ $l_{eff,II} = \pi m_x + w + 2e_1$ $l_{eff,III} = 2(\pi m_x + e_1)$ $l_{eff,IV} = \pi m_x + 2(e_1 + e_2)$	$l_{eff,V} = 2m_x + 0,625e_x + (e_1 + e_2)$ $l_{eff,VI} = 4m_x + 1,25e_x + e_1$ $l_{eff,VII} = 2m_x + 0,625e_x + e_1 + 0,5w$ $l_{eff,VIII} = 0,5(2e_1 + 2e_2 + w)$
Inner bolt row	$l_{eff,c} = l_{eff,X} = 4\pi m_1$	$l_{eff,IX} = 8m_x + 2,5e_x$ $l_{eff,nc} = l_{eff,XI} = \alpha m_1$

Some examples of possible yield patterns for the considered bolt rows are illustrated in Figure 5; all the possible yield patterns are described in details in [3].

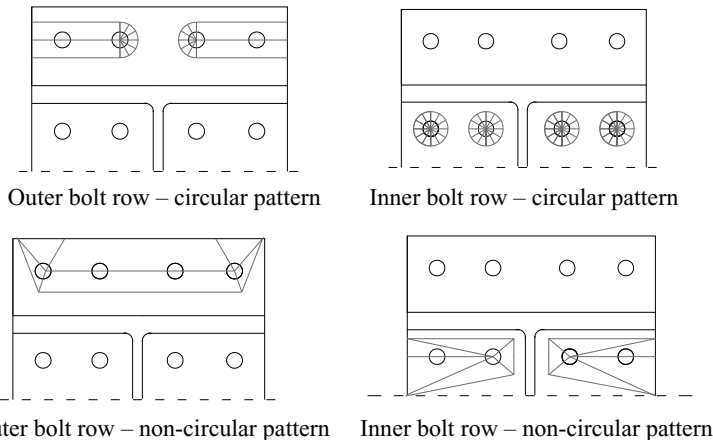

Figure 5. Examples of possible plastic yield patterns for outer and inner bolt rows with four bolts per row.

It is important to notice that a fundamental difference exists in the definition of the equivalent T-stub for the outer and inner bolt rows:

- for an outer bolt row, the T-stub to be considered is a T-stub with two bolts (the T-stub web is the beam flange); the presence of four bolts within this row only influence the values of the effective lengths.
- for an inner bolt row, the T-stub to be considered is a T-stub with four bolts (the T-stub web is the beam web).

With the so-defined effective lengths and the resistance formulas presented in the previous paragraph, it is possible to apply the component method to connections with four bolts per row. This analytical model is validated in the following paragraph.

### 3 VALIDATION OF THE PROPOSED ANALYTICAL MODEL

Within the German national project AiF-Projekt 15059 [5], tests on connections with four bolts per row were performed at the University of Dortmund and the proposed analytical model was validated through comparisons with these experimental results. This validation is briefly described here after.

#### 3.1 Experimental tests performed in Dortmund

In total, 24 experimental tests on beam splices with end-plate connections with four bolts per row were performed at the University of Dortmund [5]. The tested specimens are illustrated in Figure 6. The parameters which were varied are (each configuration was tested twice):

- the number of bolt rows:
  - flush end-plate connection (Type A), i.e. without an outer bolt row and;
  - extended end-plate connection (Type B), i.e. with an outer bolt row.
- the thickness of the end-plate: 10 mm or 20 mm and;
- the width of the beam flange: 125 mm, 170 mm or 220 mm.

Table 3 summarizes the tested joint configurations with their associated name. The testing setup is presented in Figure 6. All the measurements performed during the experimental tests were made available by the University of Dortmund. These results were analysed in details and moment-rotation ( $M - \phi$ ) curves of the joints were derived for each test. The latter were used to validate the analytical model.

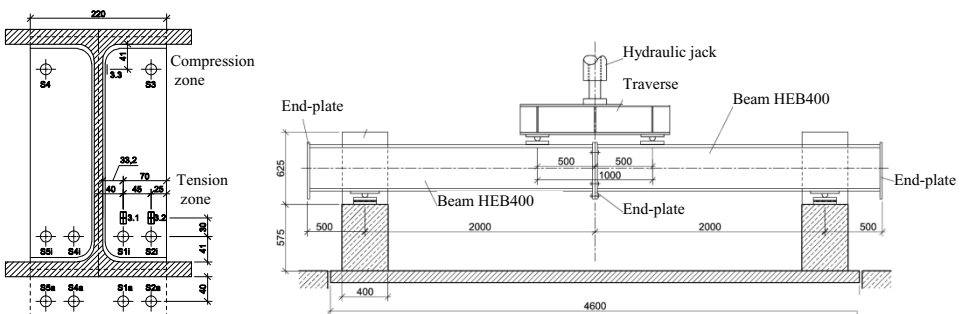

Figure 6: Tested connection configuration (with or without outer bolt row) and testing setup [5]

Table 3. Experimental test campaign

Flange width	Flush end-plate (Type A)				Extended end-plate (Type B)			
	End-plate thickness		End-plate thickness		End-plate thickness		End-plate thickness	
	10 mm	20 mm	10 mm	20 mm	10 mm	20 mm	10 mm	20 mm
220 mm	A01-1	A01-2	A04-1	A04-2	B01-1	B01-2	B04-1	B04-2
170 mm	A02-1	A02-2	A05-1	A05-2	B02-1	B02-2	B05-1	B05-2
125 mm	A03-1	A03-2	A06-1	A06-2	B03-1	B03-1	B06-1	B06-2

### 3.2 Analytical predictions vs. experimental results comparisons

The analytical predictions have been performed using the component method with the proposed modifications. The mechanical properties of the materials used in the analytical model are the actual ones, i.e. those obtained through coupon tests without safety coefficients. For the geometrical properties, the nominal ones have been used as the actual dimensions of the specimens (measured in Dortmund) were in very good agreement with the nominal ones. The analytical predictions have been compared to all the test results. Some comparisons are illustrated in Figure 7; the others are reported in [3].

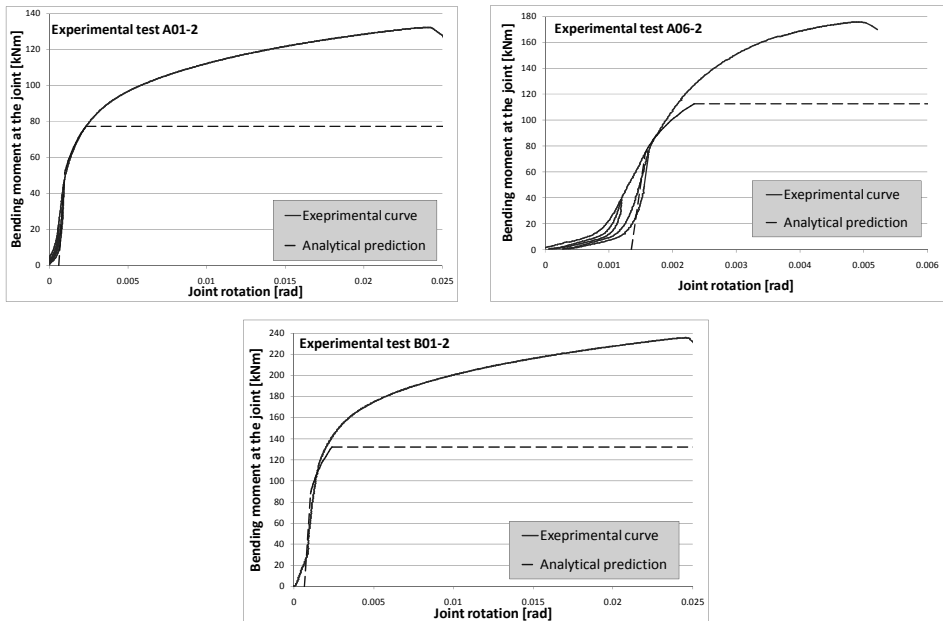

Figure 7. Examples of comparisons between analytical predictions and experimental results

Through the performed comparisons, it is observed that the analytical model gives an accurate prediction of the initial stiffness and the plastic resistance of the joints for most of the tested specimens. It is also the case for the other comparisons reported in [3]. The predicted resistant moments are close to the experimental ones (and always on the safe side) for all the tests and the computed initial stiffness are quite similar to the ones observed through the experimental curves. The curves representing the experimental behaviour of the tested joints show slip and settlements of the test setup. Obviously, for the comparison of analytical curves with the experimental curves these initial deformations must not be taken into account.

## 4 CONCLUSIONS

Eurocode 3 Part 1-8 provides detailed application rules for the design of bolted end-plate connections; most of them are limited to configurations with two bolts only in each horizontal row. However, it is sometimes more economical to place four bolts in one row, for instance when wide flange H-sections are used. This configuration is commonly met in some different countries and, in particular, in Germany where this configuration is even standardized.

Within the present article, an analytical method able to predict the response of connections with four bolts per row and in full agreement with the rules recommended in the Eurocodes has been presented and validated. In particular, the effects of the presence of four bolts per row on the T-stub model have been described and new analytical formulas have been proposed (i) for the definition of the possible effective lengths and (ii) to predict the failure modes for T-stub with four bolts. The proposed analytical method has been validated through comparisons to experimental tests performed at the University of Dortmund. Through the performed comparisons, it was demonstrated that the analytical model is able to predict with a relatively good accuracy the resistant moment and the initial stiffness of connections with four bolts per row; in particular, the analytically predicted resistant moment is always on the safe side.

The proposed model based on the component method is universal and could be easily extended to other types of connections with four bolts per row than the ones considered in the presented study (connections with stiffeners between the bolts, connections with bolt rows which are close and in which group effects may develop, ...).

## ACKNOWLEDGEMENT

The AIF project 15059 [5] has been funded by the German Ministry for Economy and Technology (Bundesministerium für Wirtschaft und Technologie – BMWi).

## REFERENCES

- [1] EN 1993-1-8. Eurocode 3: Design of steel structures – Part 1-8: Design of joints. European committee for standardization, May 2005.
- [2] Zoetemeijer P., “A design method for the tension side of statically loaded bolted beam-to-column connections”, Heron, Delft University, Vol. 20, n° 1, 1974.
- [3] Demonceau J.-F., Weynand K., Jaspart J.-P., Müller C., “Analytical model to characterize bolted beam-to-column joints with four bolts per row”, Interim report to [5].
- [4] Jaspart J.-P., “Contribution to recent advances in the field of steel joints. Column bases and further configurations for beam-to-column joints and beam splices”, Thèse d’agrégé de l’enseignement supérieur, Liège University, 1997.
- [5] Ungermann D., Weynand K., Müller C., Oberegge O., et al.: AiF-Projekt 15059 N/2 “Entwicklung eines Bemessungsmodells für geschraubte, momententragfähige Kopfplattenverbindungen mit 4 Schrauben in einer Schraubenreihe auf der Grundlage der *EN 1993-1-8*”. Daft Final report, February 2010.
- [6] Petersen, Ch.: “Stahlbau: Grundlagen der Berechnung und baulichen Ausbildung von Stahlbauten, Vieweg-Verlag, Braunschweig, 1993.
- [7] Oberegge, O. et al.: Bemessungshilfen für profilorientiertes Konstruieren, Stahlbau-Verlagsgesellschaft, 3rd edition, Köln, 1997.